

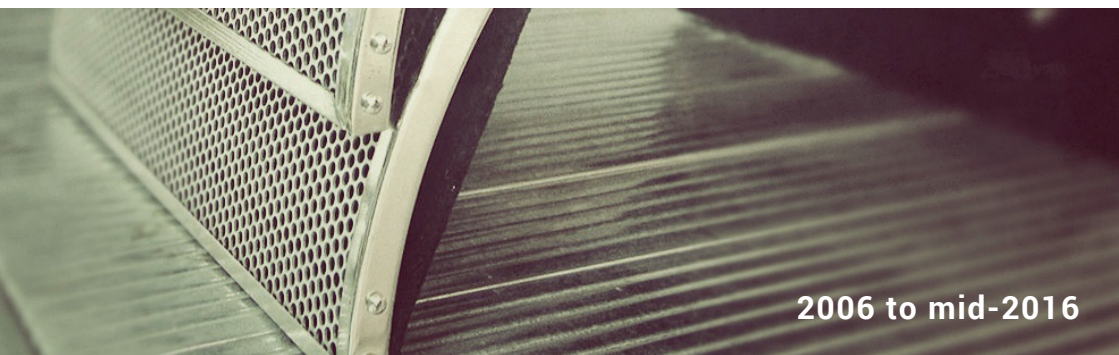

sE Electronics



REFLEXION FILTER® PRO ASSEMBLY + USE



2006 to mid-2016



Thank you for purchasing an sE Electronics RF Pro! We hope it helps make your tracks sound great - no matter WHERE you're recording.

STEP ONE

The first step is to attach the hardware to the stand, which is done by fitting the mic stand between the two rubber-sided blocks (a), and tightening the turning key (b) until the clamp is securely fixed to the mic stand.

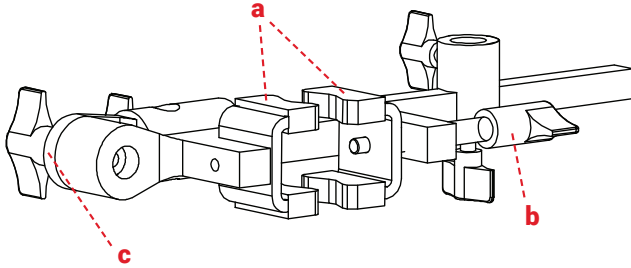

The clamp also has a large barreled hinge with a turning key (c) which allows the mechanism to turn back on itself so that the filter's weight is kept over the mic stand - rather than in front of it. This should be hinged fully back so the whole assembly is in balance, and the Reflexion Filter is then positioned as close as possible to the center of gravity on the mic stand.

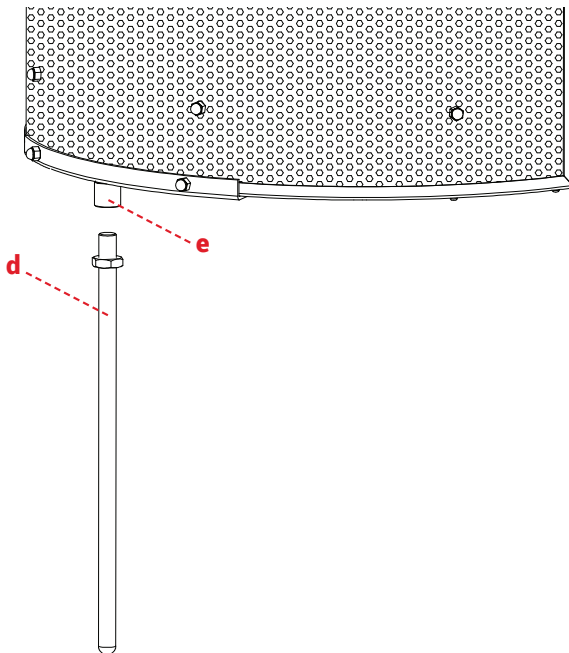

STEP TWO

Fix the support rod (d) to the Reflexion Filter by screwing it into the socket on the bottom edge (e). Tighten the nut using the wrench supplied in the box.

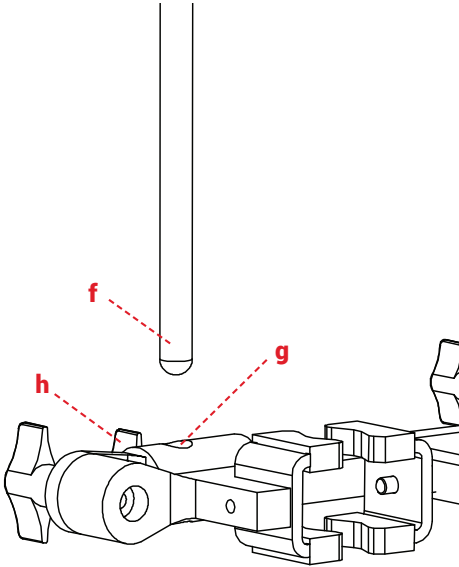

STEP THREE

Now, attach the Reflexion Filter to the mounting hardware by pushing the support rod (f) down into its socket on the stand clamp (g), and tighten it in place with the turning key on the block (h).

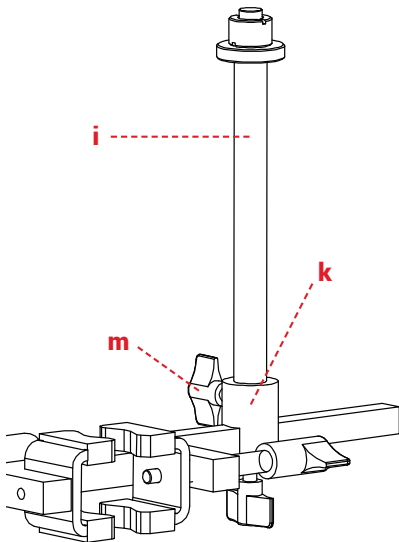

STEP FOUR

Fit the standoff (i) into the movable slot (k) on the bracket's arm and tighten it with the small turning key (m). Your microphone, in a shockmount or a clip, will attach to the top of this standoff.

**The included adapter must be used for 5/8" (US standard) threaded mounts.*



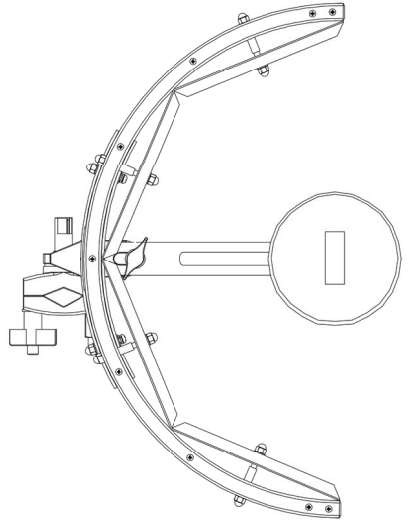
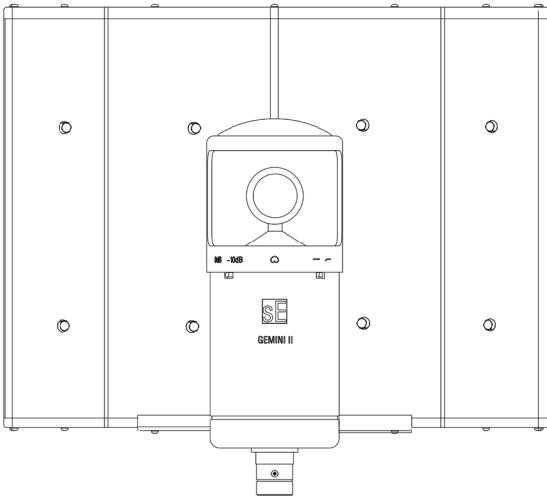

The ideal placement for your microphone is where the mic's capsule is approximately even with the front edge of the filter, and centered vertically with the filter – but some mics sound better when pushed a little closer, and some a little further away.

Once you've found a good position for the mic and filter, you can loosen the lever on top of the mic stand mount to move the filter and mic assembly forward or back – this way, you can position it so its center of gravity is balanced directly above the mic stand.

Thank you for being an sE customer - enjoy your new Reflexion Filter@!

For more information, and to register for your extra year of warranty, please visit seelectronics.com.